

REVISIONS

NO.	DATE	ECN #	REMARKS	BY	APPD.
1	11-20-98		ADDED METRIC DIMS.	CJT	LHE
2	7-27-99		CHANGED MATERIAL NOTE.	CJT	LHE
3	5-13-08	HJ08-106	ADDED OIL NOTE.	CJT	LHE
4	5-29-08	HJ08-116	ADDED C-1050 MATERIAL.	CJT	JFS

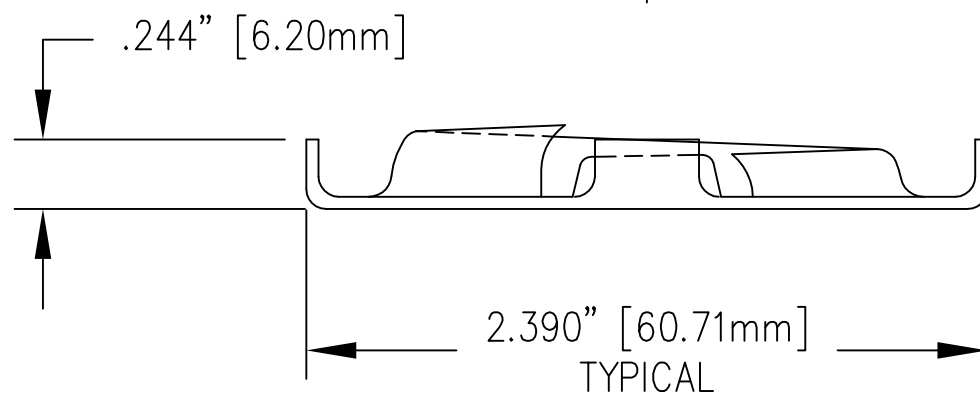
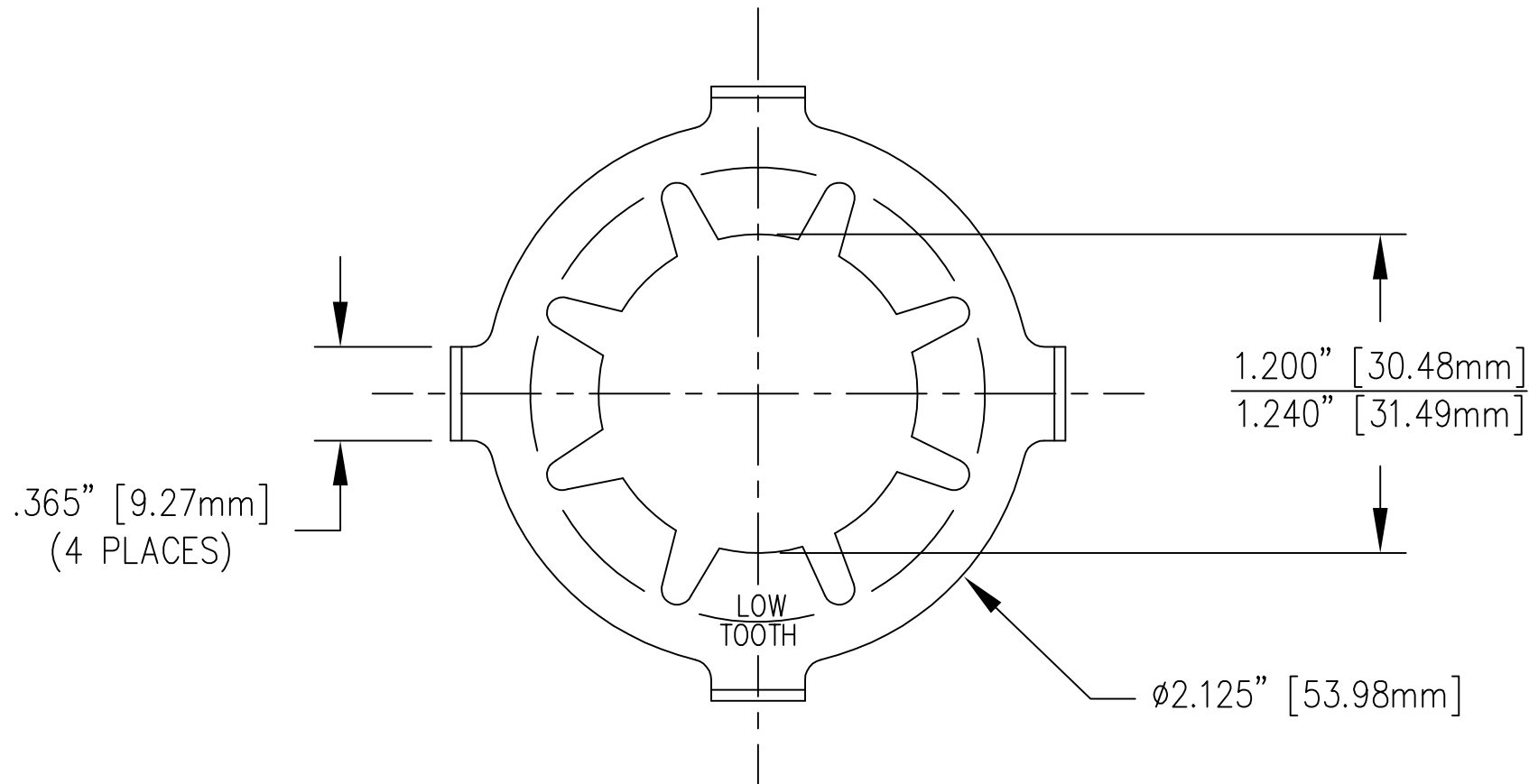

$\triangle 2 \triangle 4$ MATERIAL:
 N2-HOT ROLLED STEEL AISI C-1045 OR C-1050
 HEAT TREAT TO ROCKWELL "C" 44-48

$\triangle 2 \triangle 3$ FINISH:
 BLACK OXIDE COATING W/THIN FILM OF OIL

TOLERANCES (EXCEPT AS NOTED)
DECIMAL $\pm .032''/.8mm$
FRACTIONAL \pm
ANGULAR $\pm 2^\circ$



H-J ENTERPRISES, INC.
 3010 HIGH RIDGE BLVD. HIGH RIDGE, MO. 63049 USA
 PHONE 1-636-677-3421 FAX 1-636-376-1915

SPIN-GRIP NUT		
MATERIAL SEE DRAWING	CHK'D	APP'D
DATE 04-01-98	SCALE N.T.S.	DRAWING NO. NT0005-001

DRAWN BY
TLH